

Application: Anaerobic Digestion – Sludge Heating (Mesophilic)

There are two general types of digestion processes known as aerobic and anaerobic digestion. Aerobic uses oxygen and anaerobic is an oxygen free environment. Anaerobic digestion is a biological process that breaks down for organic solids. In this process wastewater sludge is stored in large vessels, referred to as digesters that range from 0.5 – 3.0 million gallons of storage capacity. One of the other key differences in anaerobic digestion is that heat is added to

Anaerobic Digestion

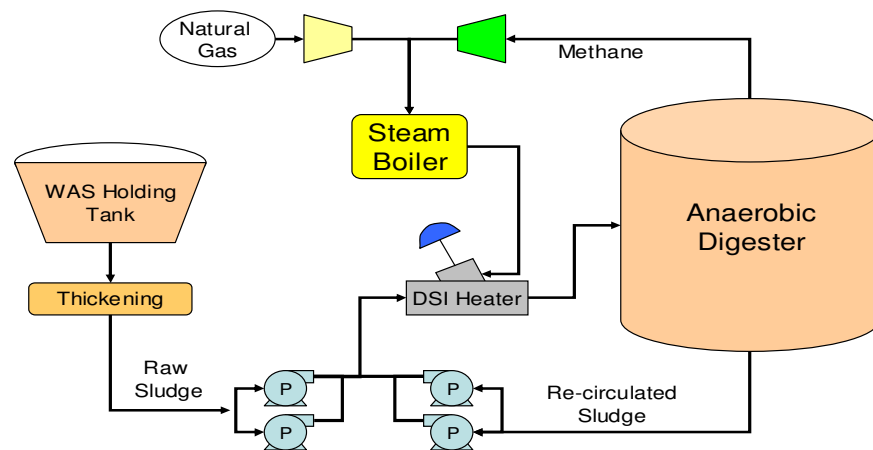

stimulate the biological activity which accelerates the process. In the mesophilic stage, temperatures are typically maintained around 96 °f. Historically heat has been added through the use of heat exchangers. Heat exchangers can face the following challenges when heating sludge:

- Wastewater sludge is scorch sensitive. When the temperature differential exceeds 50 °F between the sludge and the heating medium in heat exchangers creates hot spots can be created where sludge can burn and build-up. As the build-up increases on the tube walls, a thermal barrier is created which requires additional heat to be added thus accelerating the problem.
- Build-up problems can lead to plugging and fouling in the heat exchanger. This plugging and fouling increases maintenance costs and an increase pressure drop across the heat exchanger.
- Increased pressure drop adds demand to the sludge pumps thus increasing energy usage.

PSX Heater Solution:

A PSX heater can be used to heat both incoming sludge and sludge from the digester that is re-circulated through the DSI heater. Steam is dispersed uniformly at high velocities into the sludge which provides heat transfer instantaneously in a single pass. As the steam energy is transferred instantaneously, precise temperature control to +/- 1 °F can be maintained. As steam is injected directly, there is no thermal barrier for burn-on or build to cause plugging and fouling. The PSX can also be mounted directly in the process piping, in any orientation, thus reducing the capital costs associated with installation of heat exchangers.

Prosonix Direct Steam Injection Key Benefits:

- Reduced energy costs by lowering pressure drop and reducing demand on sludge pumps
- Reduced maintenance and increasing reliability by elimination of plugging and fouling
- Better temperature control allows for more uniform heating improving process control
- Compact heater size allows for minimal installation requirements